

Place a new magnet 'F' against the outside face of the cap that has been removed. If the magnet is 'repelled' turn it around so that it 'sticks' to the cap.

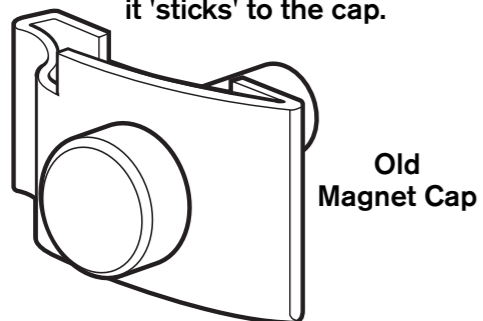

F
Magnet

Fit magnet 'F' to new cap 'C' in the same orientation

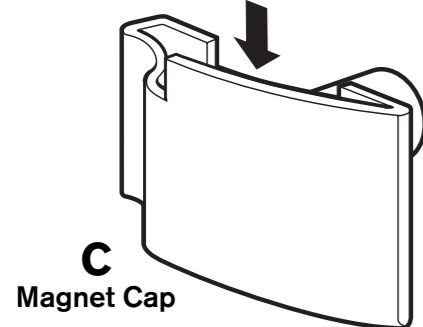

STEP 9

Fit the cap 'C' into the fixing block. Fold the panel back until the magnet caps touch. The magnets should attract each other. If they repel remove the new cap and turn the magnet around so that opposite pole is facing outwards. Fold the panel back and test again.

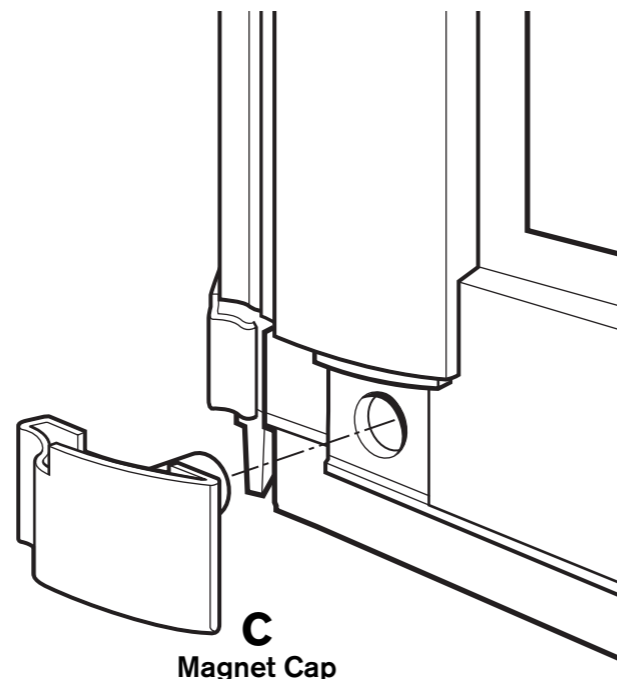

STEP 10

Fit self tapping 'G' screw in fixing block

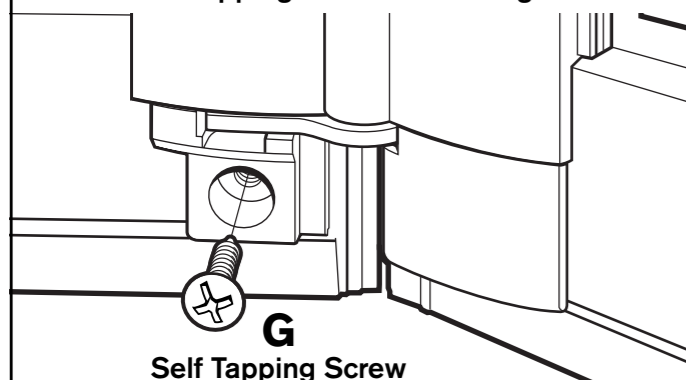

Fit new cover cap 'D'

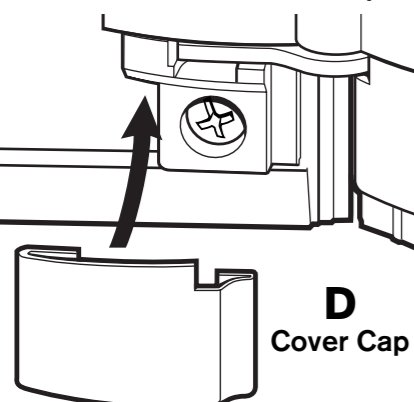

Repeat steps 9, 10 & 11 at the other end of the panel

STEP 11

On the end panel the fixing block is only at the hinge end and a different seal is fitted. Fit the seal in the same way as in steps 6 to 11 then fit end cap 'E' as below.

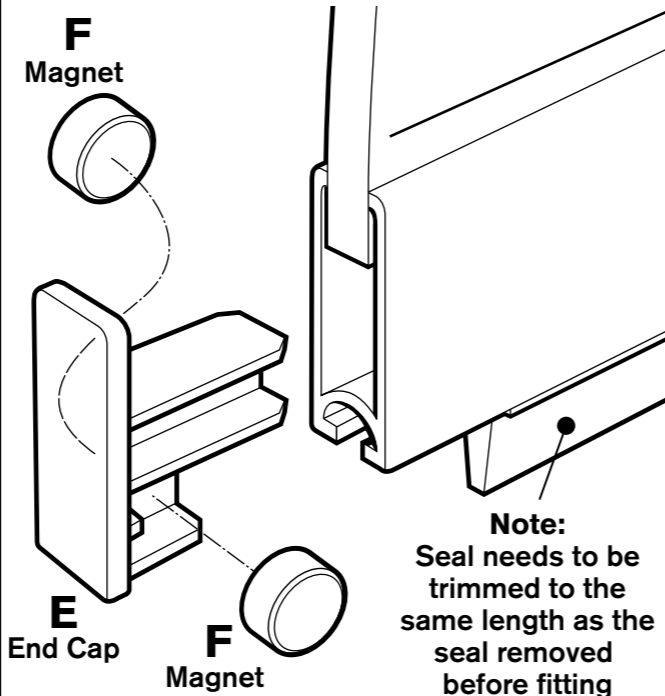

Note:
Seal needs to be trimmed to the same length as the seal removed before fitting

Magnets fit either side of the end cap and should attract each other. Compare polarity with magnets taken off

STEP 12



Bath Screen Seal Change

For Models:
051, 052, 053, 054

A Middle Panel Seal

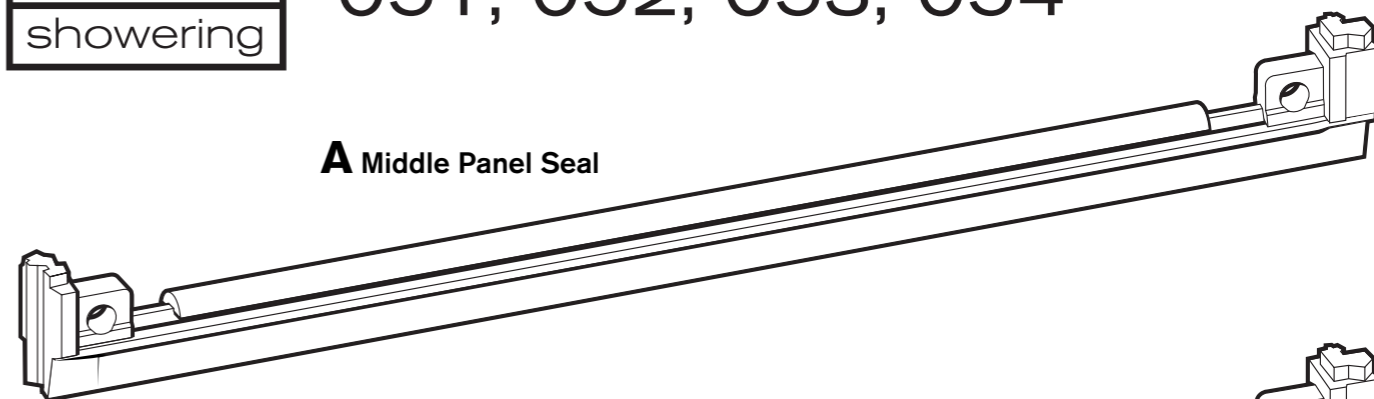

B End Panel Seal

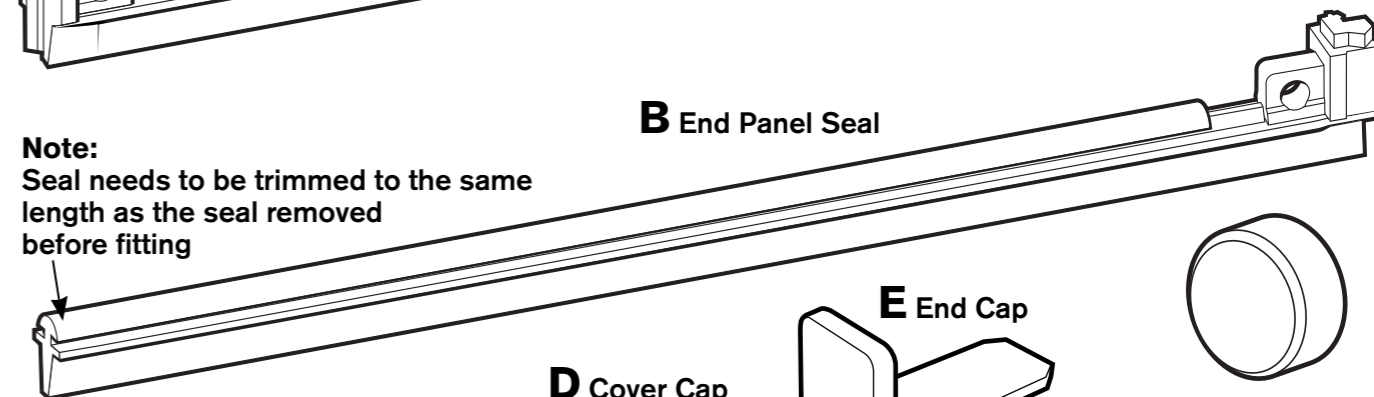

Note:
Seal needs to be trimmed to the same length as the seal removed before fitting

C Magnet Cap

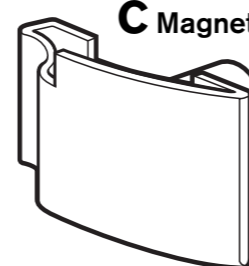

D Cover Cap

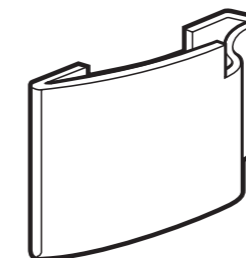

E End Cap

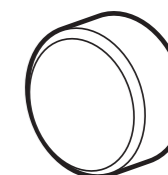
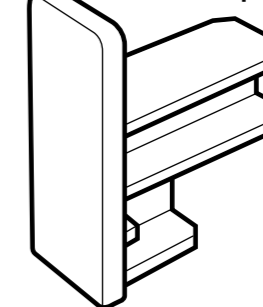

F Magnet



G Self Tapping Screw

	051	052	053	054
A Middle Panel Seal	0	0	1	2
B End Panel Seal	1	1	1	1
C Magnet Cap	1	1	2 x LH, 3 x RH	2 x LH, 3 x RH
D Cover Cap	1	1	2 x LH, 3 x RH	2 x LH, 3 x RH
E End Cap	1	1	1	1
F Magnet	0	2	4	6
G Self Tapping Screw	1	1	3	5

Components

Before installation check that all components are correctly supplied. If any parts are missing please ring the helpline. Tel: 0151 606 5000

Note: Replace seals on one panel at a time
Middle Panels only. See Step 12 for end panel.
 Carefully prise off the cover cap 'D' on the non-magnetic side. Take care not to scratch the frame.

D
Cover Cap

STEP 1

Remove the self tapping screw 'G' from the fixing block

G
Self Tapping Screw

STEP 2

Slide seal out of panel

STEP 5

Take the new seal and bend the end fixing so that the seal can slide into the channel at the bottom of the panel

Correct fitting of seal into panel

STEP 6

On the other side of the panel remove magnet cap 'C'. Repeat steps 1, 2 & 3 at the other end of the panel

C
Magnet Cap

Note: Do not dispose of old cap straight away. Keep for comparison of magnet polarity when fitting replacement

STEP 3

Slide end of seal out of the fixing by bending the seal and pushing down

Repeat procedure at other end of panel

STEP 4

Slide seal into panel until end locates in fixing block and the holes align

STEP 7

At the other end of the panel fit end of seal into the fixing block

STEP 8